

# DATASHEET

## ES-P-N2N1-5009

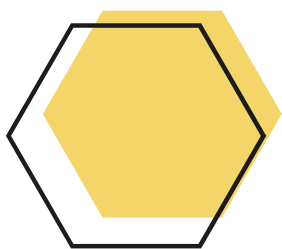

### IEEE 802.11 a/b/g/n

High-Performance,  
Dual independent  
Radio



### Quadra Band

4.9 GHz to 5.9 GHz  
supporting 4.9 GHz, UNII-  
B1,B2A,B2C and B3 Bands  
and 900 MHz ISM Band



### Industrial grade

-40 deg C to +85 deg C  
operation temperature



#### VIZMONET PTE LTD

21 Woodlands Close, #03-01, Primz Biz Hub, Singapore 737 854  
+65 6255 0581 | enquiry@vizmonet.com | <https://vizmonet.com>

LAST UPDATED ON MAY-26-24  
HW REV# 02.03

# TECHNICAL SPECIFICATION

RADIO MODULE – GENERAL INFO	
On-board Radio (11a/n) chipset MiniPCie Radio (11b/g/n) chipset	QCA 9550-AT4B (CPU) & AR 8033-AL1B (Ethernet PHY) AR 9592-AR1B
NOR Flash NAND Flash RAM	SPI Flash, 16MB NAND Flash, 256 MB DDR2, 200 MHz, 256 MB (64Mx16x2)
Operating frequency – on-board Radio Operating frequency – MiniPCie Radio	4920 MHz to 5825 MHz (Operating Channels) 902 MHz to 928 MHz (Operating frequency range)
Data rate-11n HT20/HT40-1S (SISO) Data rate-11n HT20/HT40-2S (MIMO)	6Mbps, 9Mbps, 12Mbps, 24Mbps, 36Mbps, 48Mbps,54Mbps (11a) MCS0, MCS1, MCS2, MCS3, MCS4, MCS5, MCS6, MCS7 (11n) MCS8, MCS9, MCS10, MCS11, MCS12, MCS13, MCS14, MCS15 (11n)
Channel BW - On-board Radio (11a/n) Channel BW - MiniPCie Radio (11b/g/n)	5 MHz/10 MHz/20 MHz /40 MHz 5 MHz/10 MHz/20 MHz
RoHS Compliance	Compliant
INTERFACE SPECIFICATIONS	
Power in	Power Over Ethernet
Operating Voltage	9V to 30V
RF Antenna connector	x3 MMCX Male connectors
ENVIRONMENTAL SPECIFICATIONS	
Operating Temperature Range	-40 deg C to +85 deg C
PHYSICAL SPECIFICATIONS	
Mechanical Dimension	(L) 111.5 mm x (W) 98.55 mm
Weight	TBD
REGULATORY INFORMATION	
Compliance	TBD
PACKAGING INFORMATION	
No of units	TBD

ORDERING INFORMATION

ES1-5050CSE-TOTAL-0203

OEM PCB Assembly Kit, ES-P-N2N1-5009, HW Rev 03.00  
SBC, 5 GHz, MIMO, HW Rev 2001.0300  
MiniPCIe, 900 MHz, SISO, HW Rev 2005.0300

## RADIO SPECIFICATION

### TX/RX Specification – 4920MHz to 4990 MHz (on-board radio)

Sensitivity tested in ART Mode, PSR >=95%, Chain0+Chain1

TX Power Setting = Calibrated Power level in dBm

Current consumption is measured at the input of the SBC, and it includes idle current drawn by the system

Data Rate	TX Power (dBm)	Current 24V (A)	RX Sensitivity (dBm)
54 Mbps	19	0.30	-77
48 Mbps	22	0.34	-80
36 Mbps	23	0.35	-83
24 Mbps	24	0.37	-85
18 Mbps	24	0.37	-87
12Mbps	24	0.37	-89
9 Mbps	24	0.37	-92
6 Mbps	24	0.37	-94
HT20-MCS7	18	0.29	-71
HT20-MCS6	19	0.30	-74
HT20-MCS5	20	0.31	-75
HT20-MCS4	23	0.35	-79
HT20-MCS3	24	0.37	-82
HT20-MCS2	24	0.37	-86
HT20-MCS1	24	0.37	-88
HT20-MCS0	26	0.40	-92
HT40-MCS7	18	0.29	-68
HT40-MCS6	19	0.30	-71
HT40-MCS5	20	0.31	-72
HT40-MCS4	23	0.35	-75
HT40-MCS3	24	0.37	-76
HT40-MCS2	24	0.37	-83
HT40-MCS1	24	0.37	-85
HT40-MCS0	26	0.40	-89

**TX/RX Specification – 5180 MHz to 5320 MHz (on-board radio)**

Sensitivity tested in ART Mode, PSR >=95%, Chain0+Chain1

TX Power Setting = Calibrated Power level in dBm

Current consumption is measured at the input of the SBC, and it includes idle current drawn by the system

Data Rate	TX Power (dBm)	Current 24V (A)	RX Sensitivity (dBm)
54 Mbps	21	0.32	-77
48 Mbps	22	0.34	-80
36 Mbps	23	0.35	-83
24 Mbps	25	0.38	-85
18 Mbps	25	0.38	-87
12Mbps	25	0.38	-89
9 Mbps	25	0.38	-92
6 Mbps	25	0.38	-94
HT20-MCS7	20	0.31	-71
HT20-MCS6	21	0.32	-74
HT20-MCS5	22	0.34	-75
HT20-MCS4	23	0.35	-79
HT20-MCS3	24	0.37	-82
HT20-MCS2	24	0.37	-86
HT20-MCS1	24	0.37	-88
HT20-MCS0	26	0.40	-92
HT40-MCS7	20	0.31	-68
HT40-MCS6	21	0.32	-71
HT40-MCS5	22	0.34	-72
HT40-MCS4	23	0.35	-75
HT40-MCS3	24	0.37	-76
HT40-MCS2	24	0.37	-83
HT40-MCS1	24	0.37	-85
HT40-MCS0	26	0.40	-89

**TX/RX Specification – 5500 MHz to 5720 MHz (on-board radio)**

Sensitivity tested in ART Mode, PSR >=95%, Chain0+Chain1  
 TX Power Setting = Calibrated Power level in dBm  
 Current consumption is measured at the input of the SBC, and it includes idle current drawn by the system

Data Rate	TX Power (dBm)	Current 24V (A)	RX Sensitivity (dBm)
54 Mbps	20	0.31	-77
48 Mbps	22	0.34	-80
36 Mbps	23	0.35	-83
24 Mbps	25	0.38	-85
18 Mbps	25	0.38	-87
12Mbps	25	0.38	-89
9 Mbps	25	0.38	-92
6 Mbps	25	0.38	-94
HT20-MCS7	19	0.30	-71
HT20-MCS6	20	0.31	-74
HT20-MCS5	21	0.32	-75
HT20-MCS4	22	0.34	-79
HT20-MCS3	24	0.37	-82
HT20-MCS2	24	0.37	-86
HT20-MCS1	24	0.37	-88
HT20-MCS0	26	0.40	-92
HT40-MCS7	19	0.30	-68
HT40-MCS6	20	0.31	-71
HT40-MCS5	21	0.32	-72
HT40-MCS4	22	0.34	-75
HT40-MCS3	24	0.37	-76
HT40-MCS2	24	0.37	-83
HT40-MCS1	24	0.37	-85
HT40-MCS0	26	0.40	-89

**TX/RX Specification – 5745 MHz to 5825 MHz (on-board radio)**

Sensitivity tested in ART Mode, PSR >=95%, Chain0+Chain1  
 TX Power Setting = Calibrated Power level in dBm  
 Current consumption is measured at the input of the SBC, and it includes idle current drawn by the system

Data Rate	TX Power (dBm)	Current 24V (A)	RX Sensitivity (dBm)
54 Mbps	21	0.32	-77
48 Mbps	22	0.34	-80
36 Mbps	23	0.35	-83
24 Mbps	25	0.38	-85
18 Mbps	25	0.38	-87
12Mbps	25	0.38	-89
9 Mbps	25	0.38	-92
6 Mbps	25	0.38	-94
HT20-MCS7	20	0.31	-71
HT20-MCS6	21	0.32	-74
HT20-MCS5	22	0.34	-75
HT20-MCS4	23	0.35	-79
HT20-MCS3	24	0.37	-82
HT20-MCS2	24	0.37	-86
HT20-MCS1	24	0.37	-88
HT20-MCS0	26	0.40	-92
HT40-MCS7	20	0.31	-68
HT40-MCS6	21	0.32	-71
HT40-MCS5	22	0.34	-72
HT40-MCS4	23	0.35	-75
HT40-MCS3	24	0.37	-76
HT40-MCS2	24	0.37	-83
HT40-MCS1	24	0.37	-85
HT40-MCS0	26	0.40	-89

**TX/RX Specification – 902 MHz to 928 MHz**

Sensitivity tested in ART Mode, PSR >=95%

TX Power and Sensitivity Tolerance = +/- 2 dBm

Current consumption is measured at the input of the SBC with the mini-PCIe radio module connected to it. The current consumption figures are then adjusted so that they only include extra current drawn by the mini-PCIe radio module.

Data Rate	TX Power per chain (dBm)	DC Power at 24V (W)	RX Sensitivity (dBm)
54 Mbps	20	2.2	-74
48 Mbps	22	2.4	-77
36 Mbps	24	2.6	-79
24 Mbps	26	2.9	-82
18 Mbps	26	2.9	-84
12Mbps	26	2.9	-86
9 Mbps	26	2.9	-89
6 Mbps	26	2.9	-91
11 Mbps	29	4.3	-85
5.5 Mbps	29	4.3	-90
2 Mbps	29	4.3	-92
1 Mbps	29	4.3	-93
HT20-MCS7	20	2.2	-65
HT20-MCS6	21	2.3	-67
HT20-MCS5	21	2.3	-71
HT20-MCS4	24	2.6	-75
HT20-MCS3	26	2.9	-78
HT20-MCS2	26	2.9	-81
HT20-MCS1	26	2.9	-86
HT20-MCS0	29	4.3	-88

### Channel Mapping – 902 MHz to 928 MHz

BASE BAND (MHz)	OP FREQ (MHz)	CH BW (MHz)	STANDARD (11b/g/n)
2427	907	5/10	11g/n
2432	912	5/10/20	11b/g/n
2437	917	5/10/20	11b/g/n
2442	922	5/10	11g/n

### EVM PERFORMANCE

Frequency = 912 MHz, 802.11g, 54 Mbps

Modulation Format	Bit Rate		
64QAM	54.0 Mbps		
	Average	Max	Limit
RMS EVM	-27.85 dB	-14.85 dB	-25.00 dB
	4.05 %	18.09 %	
Peak EVM	-17.02 dB	-4.48 dB at sym 8	
	14.09 %	59.67 %	
Pilot EVM	-28.80 dB	-15.69 dB	
	3.63 %	16.42 %	
Data EVM	-27.78 dB	-14.79 dB	
	4.08 %	18.23 %	
Frequency Error	-2.66 ppm	-2.67 ppm	20.00 ppm
Symbol Clock Error	-2.09 ppm	-9.60 ppm	20.00 ppm
I/Q Origin Offset	-38.96 dB	-23.57 dB	-15.00 dB
Quadrature Skew	0.09 °	-0.84 °	
IQ Gain Imbalance	-0.05 dB	-0.14 dB	
IQ Time Skew	-999.0 s	-999.0 s	
Peak Burst Power	9.98 dBm	12.13 dBm	
Avg Burst Power	1.39 dBm	8.06 dBm	
Peak-to-Avg Power Ratio	8.6 dB	9.4 dB	
Time Offset	0.14 us	0.14 us	

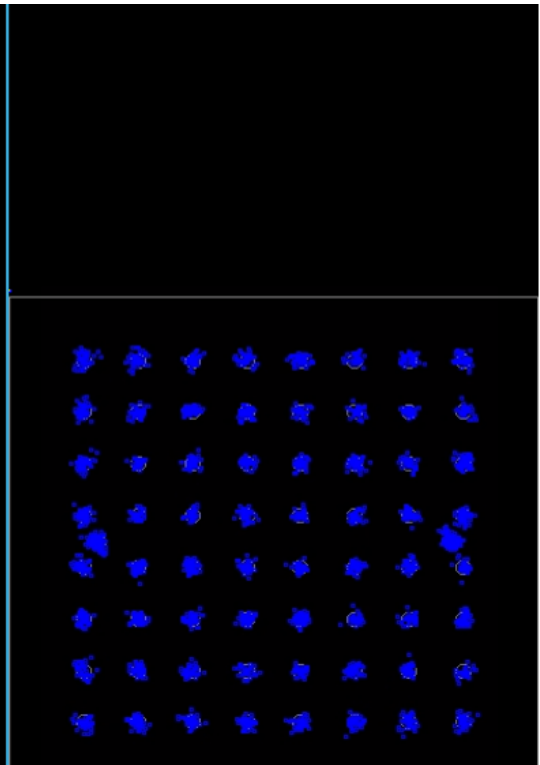



**TX/RX Specification – 5500 MHz to 5720 MHz (miniPCIe)**

Sensitivity tested in ART Mode, PSR >=95%, Chain0+Chain1  
 TX Power Setting = Calibrated Power level in dBm  
 Test Condition for Current consumption:  
 Current consumption is measured at the input of the SBC with the mini-PCIe radio module connected to it.  
 The current consumption figures are then adjusted so that they only include extra current drawn by the mini-PCIe radio module.

Data Rate	TX Power (dBm)	Current 24V (A)	RX Sensitivity (dBm)
54 Mbps	19	0.19	-77
48 Mbps	20	0.20	-80
36 Mbps	23	0.23	-82
24 Mbps	26	0.27	-85
18 Mbps	26	0.27	-87
12Mbps	26	0.27	-89
9 Mbps	26	0.27	-92
6 Mbps	26	0.27	-94
HT20-MCS7	19	0.19	-71
HT20-MCS6	20	0.20	-74
HT20-MCS5	21	0.21	-75
HT20-MCS4	23	0.23	-79
HT20-MCS3	24	0.24	-82
HT20-MCS2	24	0.24	-86
HT20-MCS1	24	0.24	-88
HT20-MCS0	26	0.27	-92
HT40-MCS7	19	0.19	-68
HT40-MCS6	20	0.20	-71
HT40-MCS5	21	0.21	-72
HT40-MCS4	23	0.23	-76
HT40-MCS3	24	0.24	-79
HT40-MCS2	24	0.24	-83
HT40-MCS1	24	0.24	-85
HT40-MCS0	26	0.27	-89

Frequency = 912 MHz, 802.11n, MCS0 (65Mbps)

Modulation Format	Bit Rate		
64QAM	65.0 Mbps		
	Average	Max	Limit
RMS EVM	-28.50 dB	-27.53 dB	-27.00 dB
	3.76 %	4.20 %	
Peak EVM	-17.67 dB	-15.36 dB at sym 36	
	13.08 %	17.06 %	
Pilot EVM	-29.55 dB	-28.16 dB	
	3.33 %	3.91 %	
Data EVM	-28.43 dB	-27.47 dB	
	3.79 %	4.23 %	
Frequency Error	-2.83 ppm	-2.85 ppm	25.00 ppm
Symbol Clock Error	-3.11 ppm	-5.86 ppm	25.00 ppm
I/Q Origin Offset	-48.50 dB	-44.45 dB	-15.00 dB
Quadrature Skew	0.47 °	0.63 °	
IQ Gain Imbalance	0.00 dB	-0.03 dB	
IQ Time Skew	43.67 ps	87.44 ps	
Peak Burst Power	9.90 dBm	10.85 dBm	
Avg Burst Power	1.10 dBm	1.19 dBm	
Peak-to-Avg Power Ratio	8.8 dB	9.8 dB	
Time Offset	0.15 us	0.15 us	

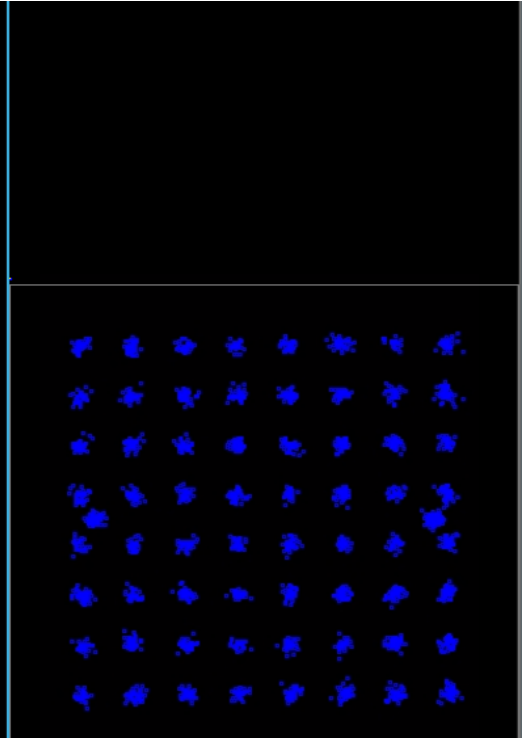

## Interference Desensitization

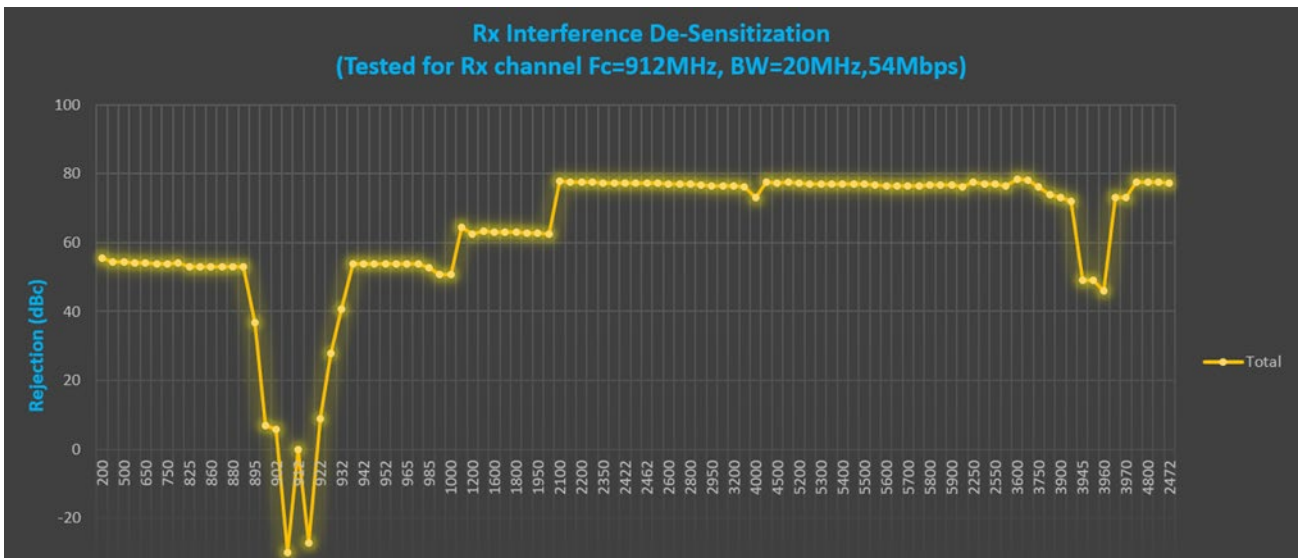

## PIN OUT DETAILS

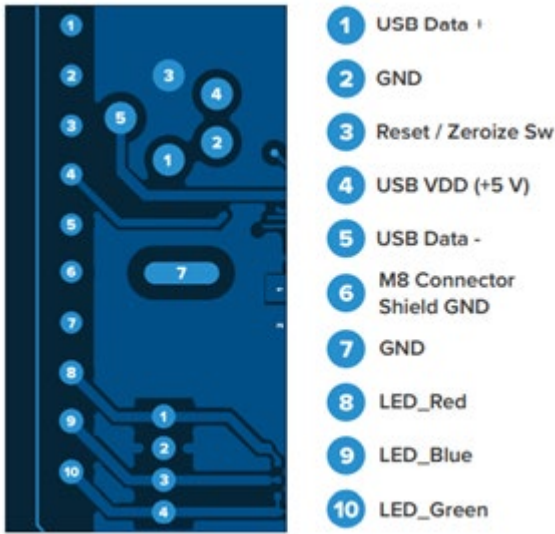

The mating connectors for DF3-10P-2DS(01) are

- PCB Mounted: DF3-10S-2DSA(25)
- Cable Housing: DF3-10S-2C

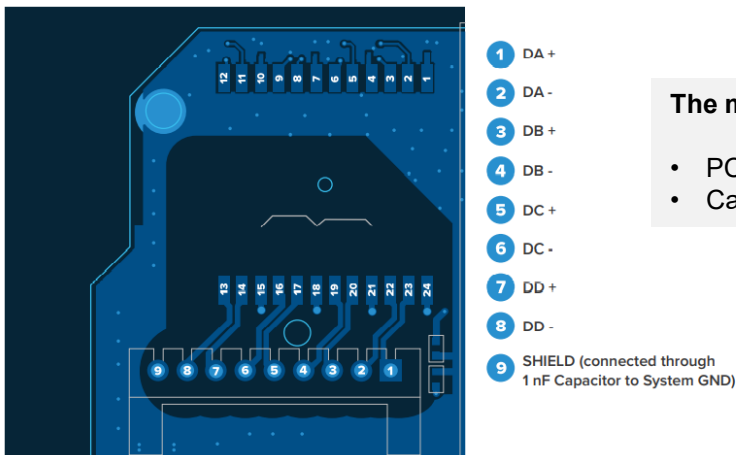

The mating connectors for DF3-9P-2DS(01) are

- PCB Mounted: DF3-9S-2DSA(25)
- Cable Housing: DF3-9S-2C

A DC power interface is provided through a 2-pin Hirose DF3-2P-2DS(01) connector with the following pinout:

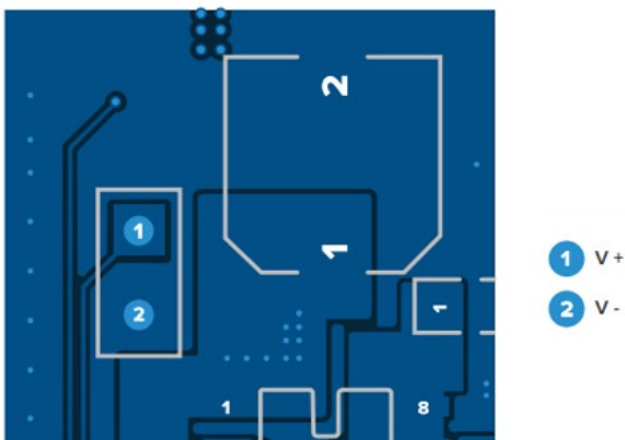

The mating connectors for DF3-2P-2DS(01) are

- PCB Mounted: DF3-2S-2DSA(25)
- Cable Housing: DF3-2S-2C

# EVAL BOARD SCHEMATIC

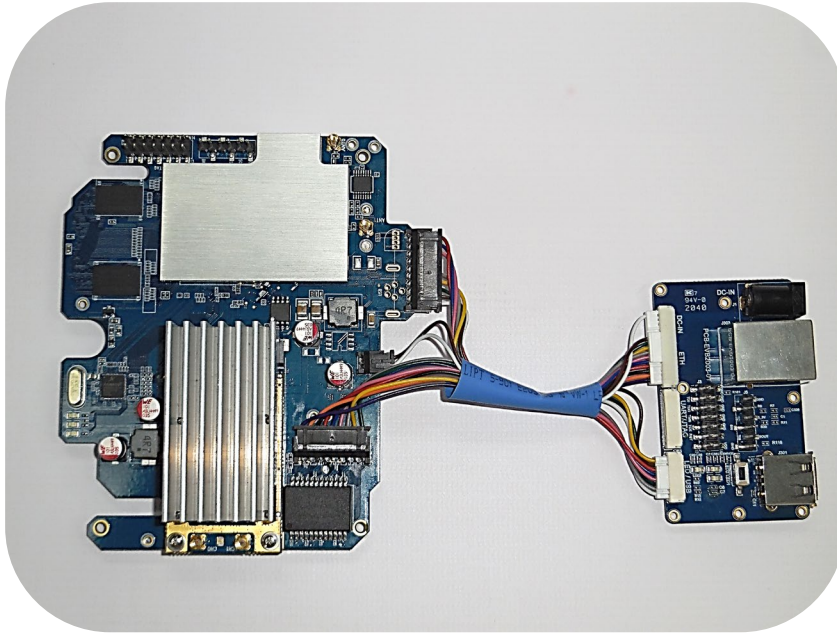

## JTAG

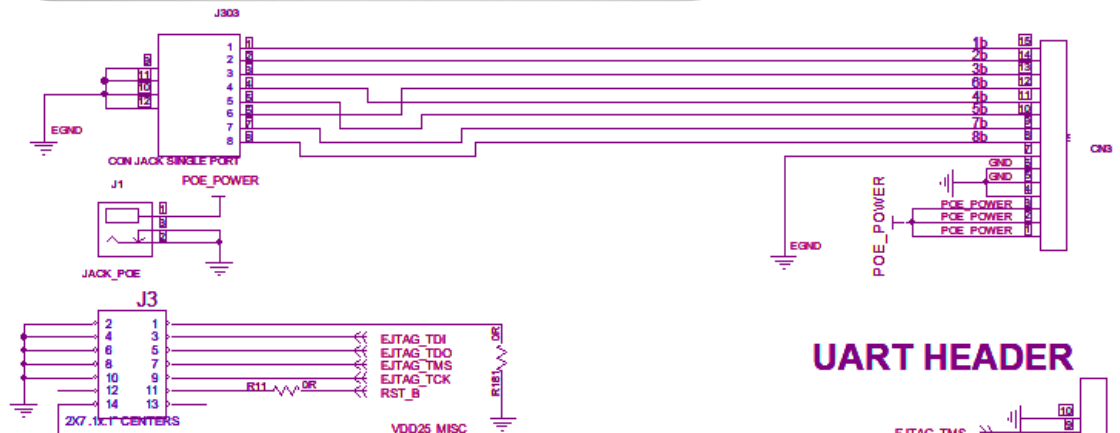

## UART

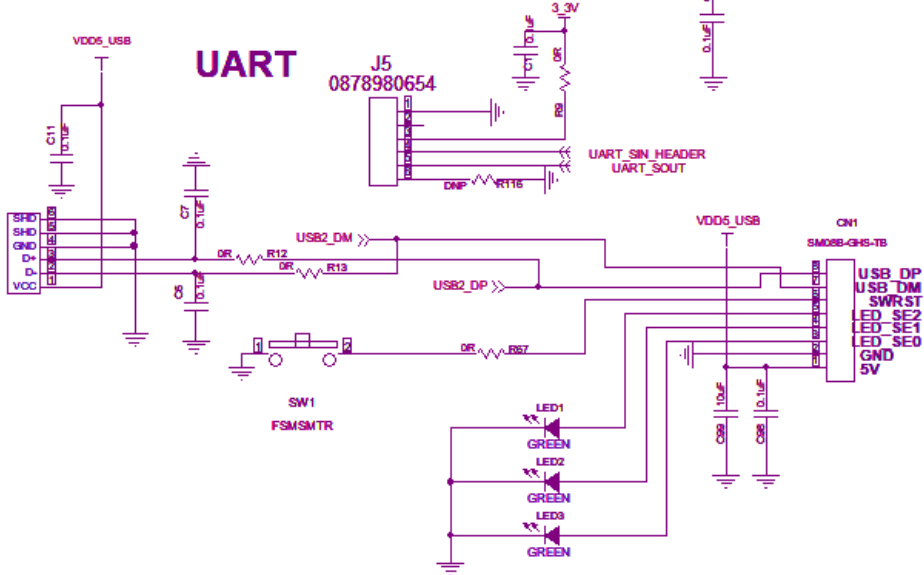

# MECHANICAL DIMENSIONS

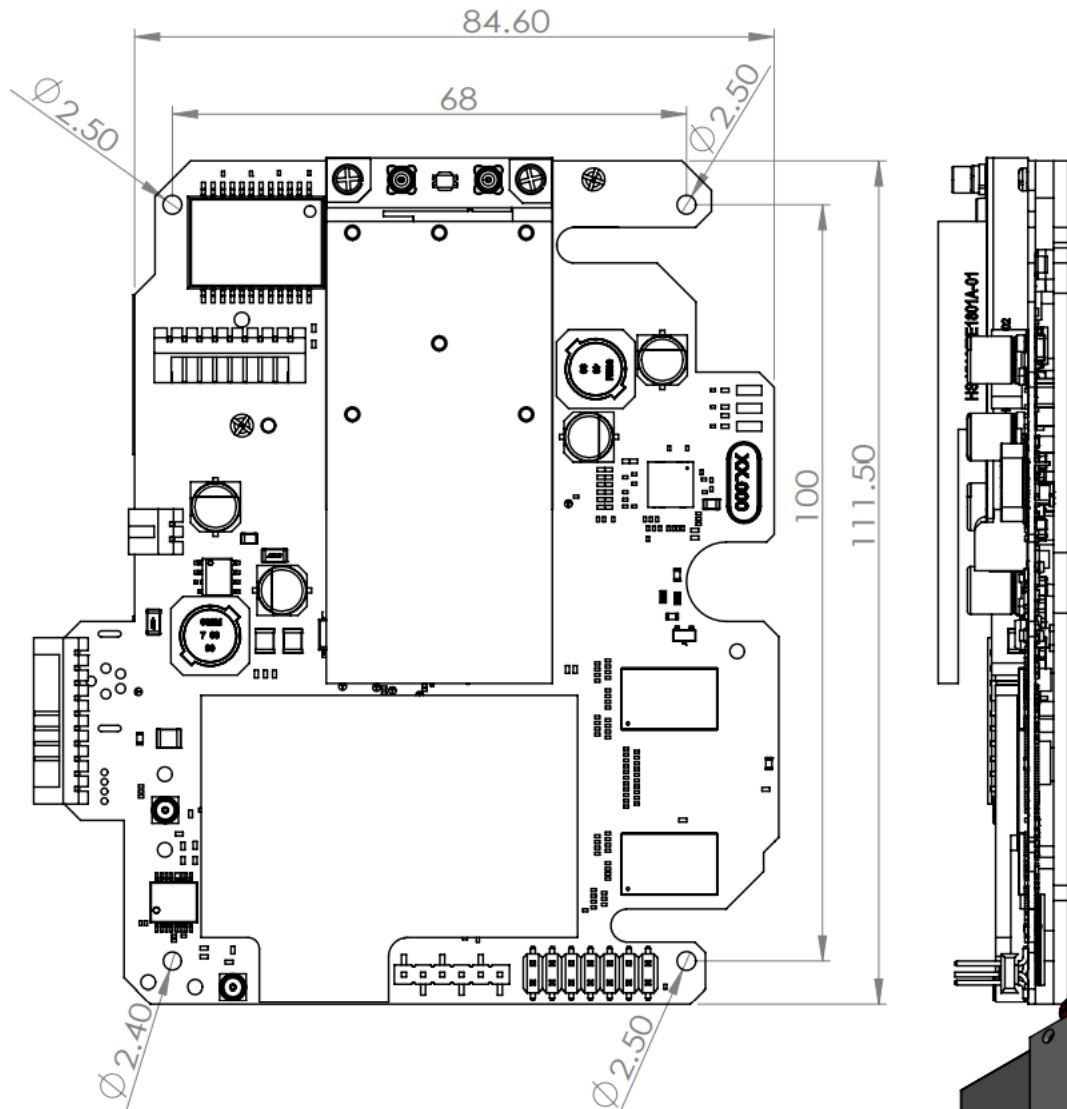

### Trademarks

The information in this document is being provided in connection with Vizmonet products, which are subject to continuous developments and improvements. While every effort is made to ensure that the information contained in this document is correct and accurate at the time of this printing, Vizmonet makes no representations or warranties with respect to the accuracy of the information and is not liable for errors or mistakes that may arise. However, Vizmonet reserves the right to make changes to specifications and product descriptions at any time without notice. Vizmonet does not assume any responsibility for the use of the described product; neither does it convey any license under its patent rights, or the rights of others. Vizmonet products are not intended, authorized, or warranted for use as components in applications intended to support or sustain life. Built-to-Customize™ is a trademark of Vizmonet. All other trademarks, registered trademarks and product names are the sole property of their respective owners.

### Contact

Web: <https://vizmonet.com>  
Email: [enquiry@vizmonet.com](mailto:enquiry@vizmonet.com)

### Headquarters

Vizmonet Pte Ltd  
21, Woodlands Close  
#03-01, Primz Biz Hub  
Singapore 737 854

HW REV# 03.00