

DATASHEET

axE4-2400

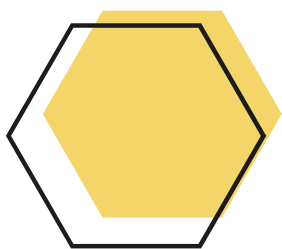

Wi-Fi 6

IEEE 802.11 b/g/n/ac/ax
4x4 MU-MIMO
MiniPCIe Radio Module



High Performance

30 dBm TX Power
2412 MHz to 2484 MHz



Industrial grade

-40 deg C to +85 deg C
operation temperature

dun & bradstreet



VIZMONET PTE LTD

21 Woodlands Close, #03-01, Primz Biz Hub, Singapore 737 854
+65 6255 0581 | enquiry@vizmonet.com | <https://vizmonet.com>

HW REV# axE42400.0100
Last updated on Apr-26-2024

CUSTOM DESIGN (Options)

Heatsink, Shield Cover and Mechanical Parts

Talk to our experts



enquiry@vizmonet.com

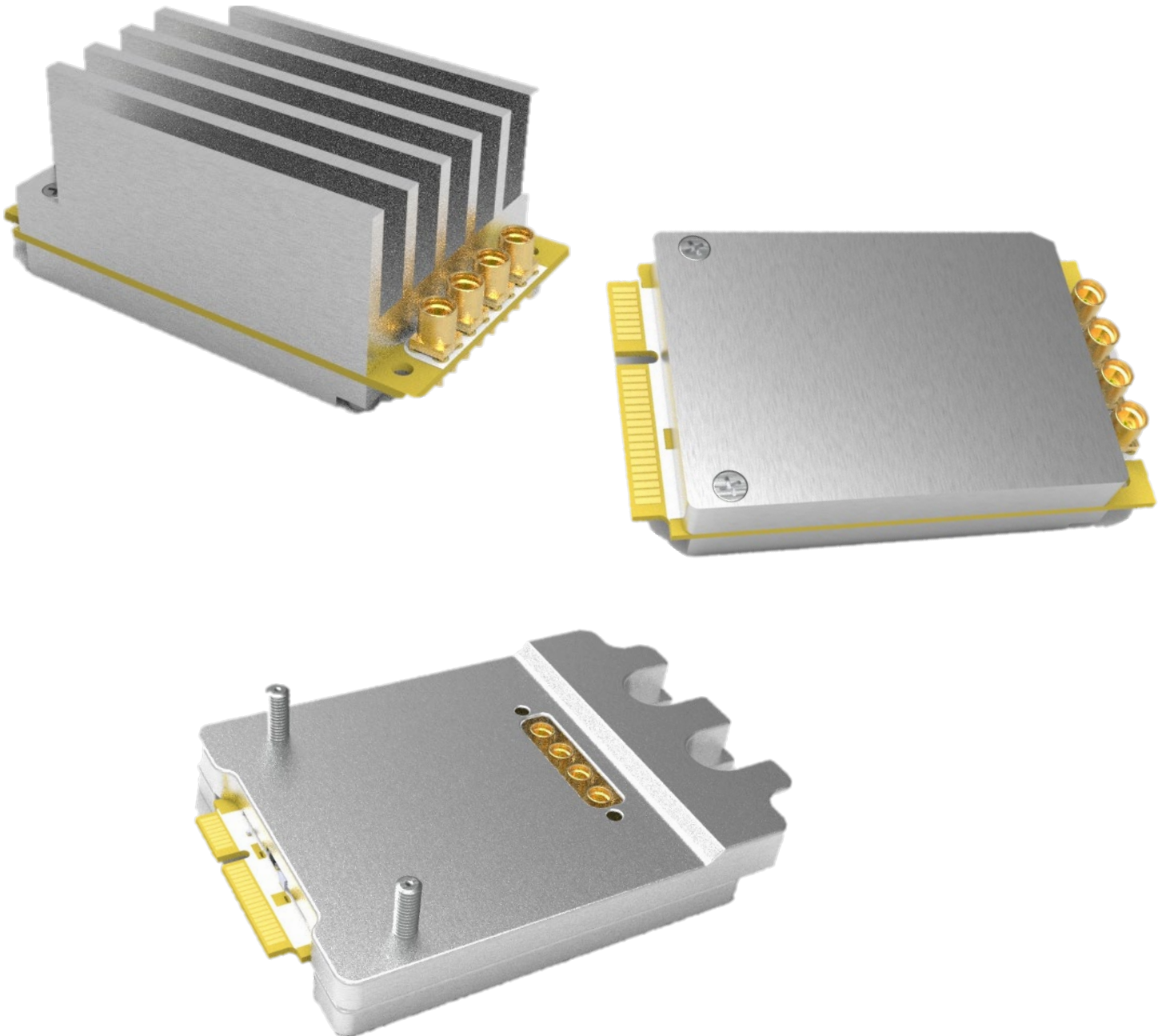

TECHNICAL SPECIFICATION

RADIO MODULE – GENERAL INFO	
Chipset	QUALCOMM QCN-9074-1
EEPROM	2-Mbit serial I ² C bus EEPROM
Host Interface	Mini PCIe interface with PCIe 3.0
Operating System	Linux, supports open source ath11K Linux driver
Security	AES-CCMP at 128/256 bits AES-GCMP at 128/256 bits WEP, TKIP hardware encryption WAPI-2 hardware encryption WPA/WPA2-Personal/WPA2-Enterprise and WPA3 Personal
Operating frequency (11b/g/n)	2412 MHz to 2484 MHz (Operating channels)
Data rate -11b	1 Mbps, 2 Mbps, 5.5 Mbps, 11 Mbps
Data rate-11g	6Mbps, 9Mbps, 12Mbps, 18 Mbps, 24Mbps, 36Mbps, 48Mbps, 54Mbps
Data rate-11n	MCS0, MCS1, MCS2, MCS3, MCS4, MCS5, MCS6, MCS7
Data rate-11ac	MCS0, MCS1, MCS2, MCS3, MCS4, MCS5, MCS6, MCS7 ,MCS8, MCS9, MCS10, MCS11
Data rate-11ax	MCS0, MCS1, MCS2, MCS3, MCS4, MCS5, MCS6, MCS7 ,MCS8, MCS9, MCS10, MCS11, MCS12, MCS13
Channel BW	5 MHz/10 MHz/20 MHz/40 MHz
Compliance	RoHS, MIL-STD-810G Shock & Vibration
MAC ID	74E277 Series
INTERFACE SPECIFICATIONS	
Operating Voltage	3.3V DC / 5V DC (through miniPCI pins 45,47,49,51 for PA)
Total DC Power Consumption	11 Watts in 4x4 MIMO mode
RF Antenna connector	x4 MMCX Female(Jack), Straight connectors
ENVIRONMENTAL SPECIFICATIONS	
Operating Temperature Range	-40 deg C to +85 deg C
PHYSICAL SPECIFICATIONS	
Mechanical Dimension	(L) 51 mm x (W) 30 mm x (W) 21mm
Weight (grams)	46
REGULATORY INFORMATION	
Compliance	Work in Progress
PACKAGING INFORMATION	
No of units	100, Shipping Carton Dimension (52 cm x 23 cm x 13 cm)

ORDERING INFORMATION

axE4-2400

Mini PCIe Radio Module, 4x4 MU-MIMO, IEEE 802.11 b/g/n/ac/ax, 2.4 GHz
30 dBm**RADIO SPECIFICATION****TX/RX Specification (11b/g) – 2412 MHz to 2462 MHz**TX Power per chain (SISO mode), ± 2 dBm.

DC power consumption is the total dc power drawn only by the miniPCIe module in 4x4 MIMO mode and it excludes the dc power drawn by the main board to which the module is connected.

RX Sensitivity per chain (SISO mode) , ± 2 dBm.

Data Rate	Modulation	TX Power (dBm)	DC Power Consumption (Watts)	RX Sensitivity (dBm)
1 Mbps	DBPSK	24	10.9	-100
2 Mbps	DQPSK	24	10.9	-97
5.5 Mbps	QPSK	24	10.9	-95
11 Mbps	QPSK	24	10.9	-91
6 Mbps	BPSK	24	10.9	-96
9 Mbps	BPSK	24	10.9	-94
12 Mbps	QPSK	24	10.9	-93
18 Mbps	QPSK	24	10.9	-91
24 Mbps	16-QAM	24	10.9	-86
36 Mbps	16-QAM	24	10.9	-83
48 Mbps	64-QAM	24	10.9	-80
54 Mbps	64-QAM	24	10.9	-78

TX/RX Specification (11n) – 2412 MHz to 2462 MHz

TX Power per chain (SISO mode), ± 2 dBm.

DC power consumption is the total dc power drawn only by the miniPCIe module in 4x4 MIMO mode and it excludes the dc power drawn by the main board to which the module is connected.

RX Sensitivity per chain (SISO mode) , ± 2 dBm.

Data Rate	Modulation	TX Power (dBm)	DC Power Consumption (Watts)	RX Sensitivity (dBm)
HT20-MCS0	BPSK	24	10.9	-94
HT20-MCS1	QPSK	24	10.9	-90
HT20-MCS2	QPSK	24	10.9	-88
HT20-MCS3	16-QAM	24	10.9	-85
HT20-MCS4	16-QAM	24	10.9	-81
HT20-MCS5	64-QAM	24	10.9	-77
HT20-MCS6	64-QAM	24	10.9	-76
HT20-MCS7	64-QAM	24	10.9	-74
HT40-MCS0	BPSK	24	10.9	-91
HT40-MCS1	QPSK	24	10.9	-87
HT40-MCS2	QPSK	24	10.9	-85
HT40-MCS3	16-QAM	24	10.9	-82
HT40-MCS4	16-QAM	23	10.5	-78
HT40-MCS5	64-QAM	23	10.5	-74
HT40-MCS6	64-QAM	23	10.5	-73
HT40-MCS7	64-QAM	23	10.5	-71

TX/RX Specification (11ac) – 2412 MHz to 2462 MHz

TX Power per chain (SISO mode), ± 2 dBm.

DC power consumption is the total dc power drawn only by the miniPCIe module in 4x4 MIMO mode and it excludes the dc power drawn by the main board to which the module is connected.

RX Sensitivity per chain (SISO mode), ± 2 dBm.

Data Rate	Modulation	TX Power (dBm)	DC Power Consumption (Watts)	RX Sensitivity (dBm)
VHT20-MCS0	BPSK	24	10.9	-96
VHT20-MCS1	QPSK	24	10.9	-94
VHT20-MCS2	QPSK	24	10.9	-92
VHT20-MCS3	16-QAM	24	10.9	-89
VHT20-MCS4	16-QAM	24	10.9	-85
VHT20-MCS5	64-QAM	24	10.9	-81
VHT20-MCS6	64-QAM	24	10.9	-80
VHT20-MCS7	64-QAM	24	10.9	-79
VHT20-MCS8	256-QAM	23	10.5	-74
VHT20-MCS9	256-QAM	23	10.5	-72
VHT20-MCS10	1024-QAM	22	10.2	-69
VHT20-MCS11	1024-QAM	22	10.2	-67
VHT40-MCS0	BPSK	24	10.9	-93
VHT40-MCS1	QPSK	24	10.9	-91
VHT40-MCS2	QPSK	24	10.9	-89
VHT40-MCS3	16-QAM	24	10.9	-86
VHT40-MCS4	16-QAM	23	10.5	-82
VHT40-MCS5	64-QAM	23	10.5	-78
VHT40-MCS6	64-QAM	23	10.5	-77
VHT40-MCS7	64-QAM	23	10.5	-76
VHT40-MCS8	256-QAM	23	10.5	-71
VHT40-MCS9	256-QAM	23	10.5	-69
VHT40-MCS10	1024-QAM	22	10.2	-66
VHT40-MCS11	1024-QAM	21	10.2	-64

TX/RX Specification (11ax) – 2412 MHz to 2462 MHz

TX Power per chain (SISO mode), ± 2 dBm.

DC power consumption is the total dc power drawn only by the miniPCIe module in 4x4 MIMO mode and it excludes the dc power drawn by the main board to which the module is connected.

RX Sensitivity per chain (SISO mode), ± 2 dBm.

Data Rate	Modulation	TX Power (dBm)	DC Power Consumption (Watts)	RX Sensitivity (dBm)
HE20-MCS0	BPSK	24	10.9	-94
HE20-MCS1	QPSK	24	10.9	-93
HE20-MCS2	QPSK	24	10.9	-91
HE20-MCS3	16-QAM	24	10.9	-89
HE20-MCS4	16-QAM	24	10.9	-85
HE20-MCS5	64-QAM	24	10.9	-81
HE20-MCS6	64-QAM	24	10.9	-80
HE20-MCS7	64-QAM	24	10.9	-78
HE20-MCS8	256-QAM	22	10.2	-75
HE20-MCS9	256-QAM	22	10.2	-73
HE20-MCS10	1024-QAM	21	9.7	-70
HE20-MCS11	1024-QAM	21	9.7	-67
HE20-MCS12	4096-QAM	20	9.2	-64
HE20-MCS13	4096-QAM	20	9.2	-60
HE40-MCS0	BPSK	24	10.9	-91
HE40-MCS1	QPSK	24	10.9	-90
HE40-MCS2	QPSK	24	10.9	-88
HE40-MCS3	16-QAM	24	10.9	-86
HE40-MCS4	16-QAM	24	10.9	-82
HE40-MCS5	64-QAM	24	10.9	-78
HE40-MCS6	64-QAM	24	10.9	-77
HE40-MCS7	64-QAM	24	10.9	-75
HE40-MCS8	256-QAM	22	10.2	-72
HE40-MCS9	256-QAM	22	10.2	-70
HE40-MCS10	1024-QAM	21	9.7	-67
HE40-MCS11	1024-QAM	21	9.7	-64
HE40-MCS12	4096-QAM	20	9.2	-61
HE40-MCS13	4096-QAM	20	9.2	-57

TX Specification

Parameter	Specification
RF Power control Step	0.5 dBm
Spectral Mask Compliance	Compliant with IEEE 802.11b/g/n/ac/ax Mask, with > 5 dB margin
EVM Compliance	Compliant with IEEE 802.11b/g/n/ac/ax EVM requirement with > 5 dB margin
Second Harmonic Spurious Emission	-30 dBC
Third Harmonic Spurious Emission	-40 dBC
Transmitter Spurious Emission	FCC PART 15C COMPLIANT

RX Specification

Parameter	Specification
Receiver Maximum input level (10% PER)	
11b, 11g < 18 Mbps, 11n/11ac/11ax < MCS5	> 2 dBm
11b, 11g > 18 Mbps, 11n/11ac/11ax > MCS5	> -10 dBm
Frequency Accuracy	Within ± 10 PPM
Receiver Adjacent Channel Rejection (ACR)	
11g, 6 Mbps	> 25 dBC
11ac, 11ax, HE40-MCS0	> 30 dBC
11ax, HE40-MCS11	> 11 dBC
Interference De-sensitization 11ax, HE20-MCS13	
400 MHz to 2350 MHz	> 50 dBC
4800 MHz to 5825 MHz	> 60 dBC

TX EVM PERFORMANCE

Frequency = 2432 MHz, TX Power=21 dBm, IEEE 802.11ax, HE20, MCS11

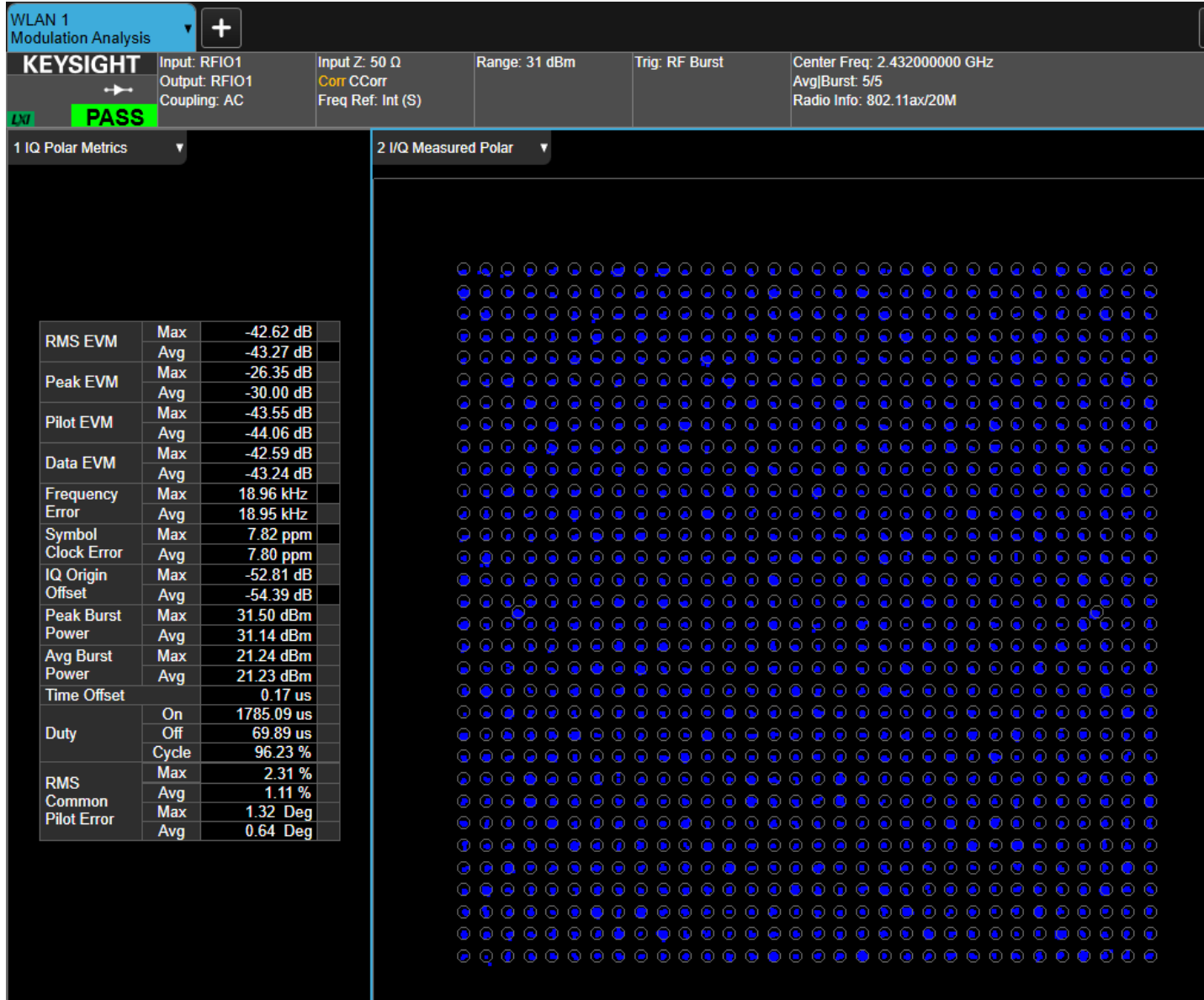

TX EVM PERFORMANCE

Frequency = 2432 MHz, TX Power = 22 dBm, IEEE 802.11ac, VHT20, MCS11

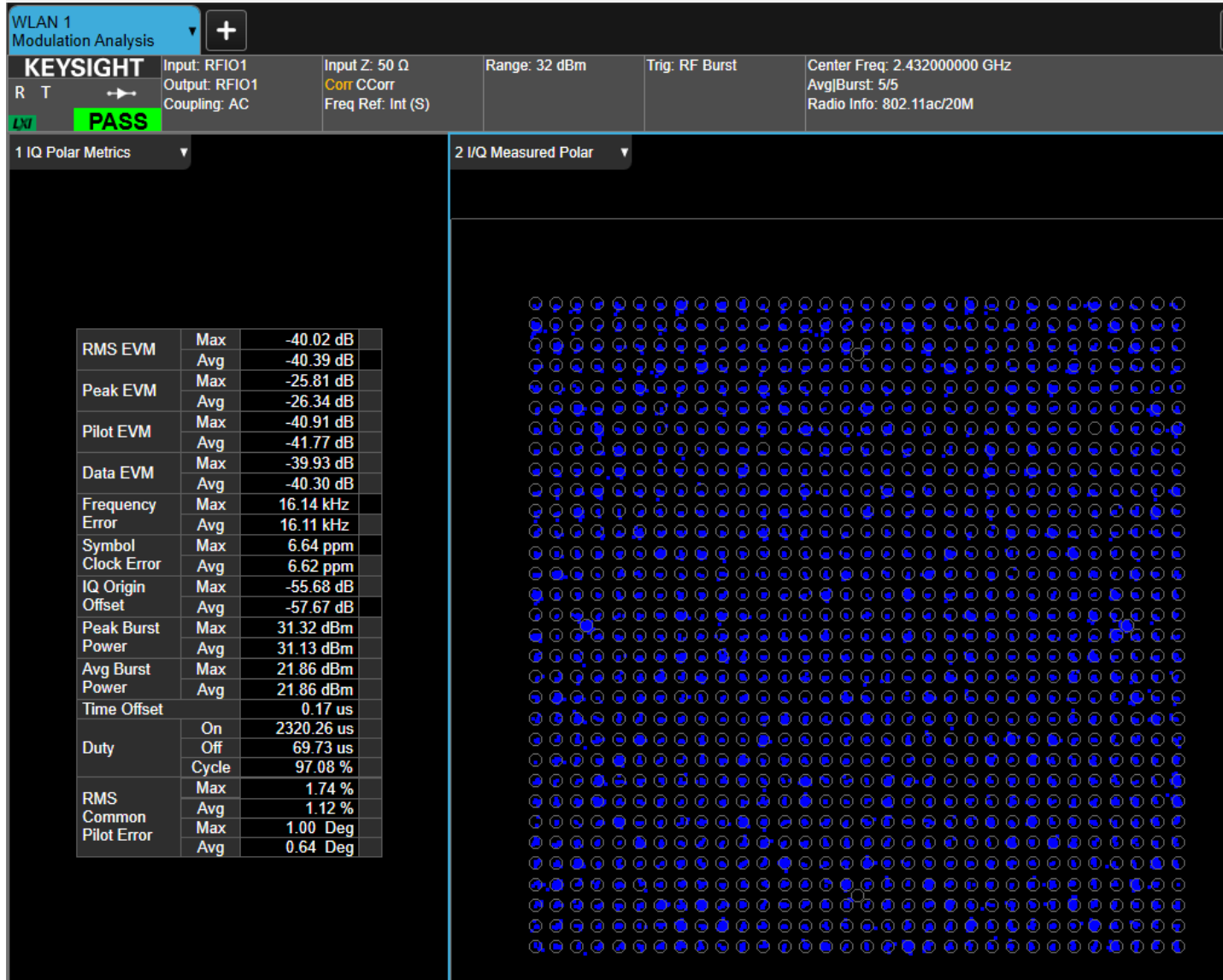

Receiver Interference Desensitization

**RX Interference DeSenstization
2432MHz, 11ax-MCS13-HE20-SISO**

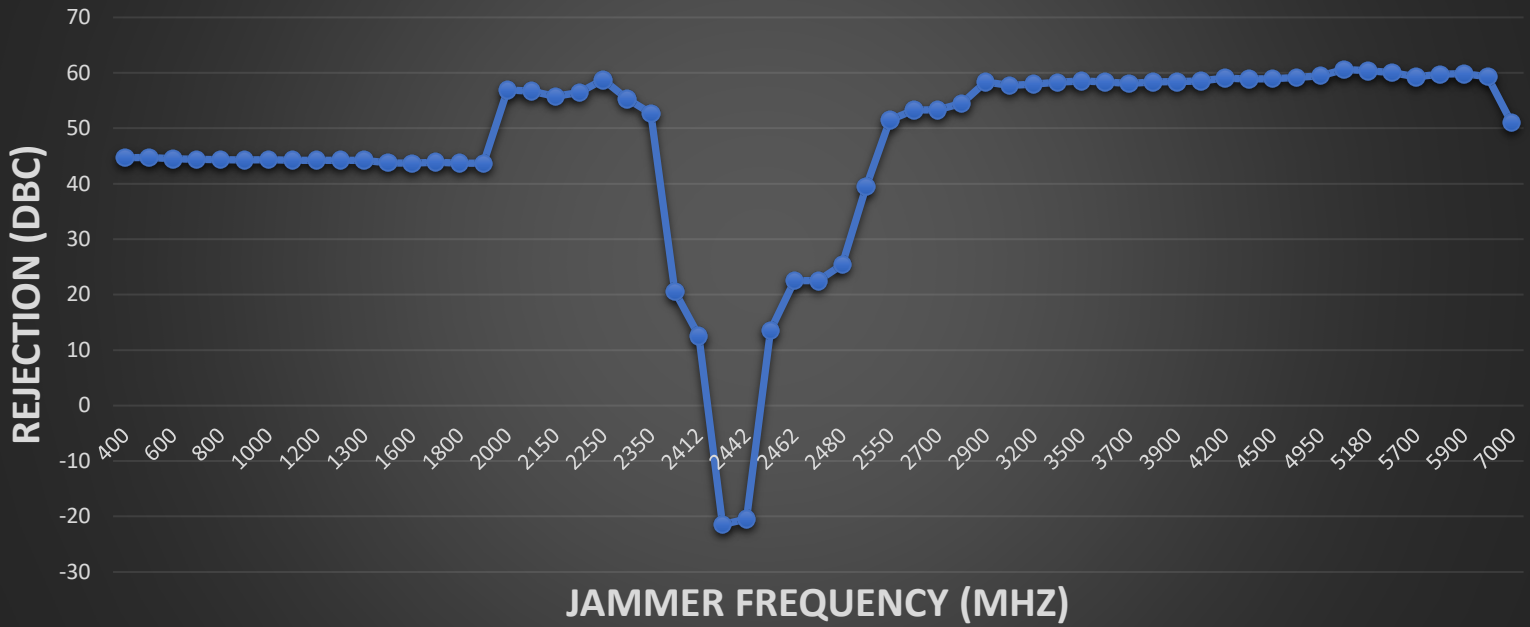

Receiver Dynamic Range

Rx Dynamic Range-SISO-BW20-11ax-MCS13

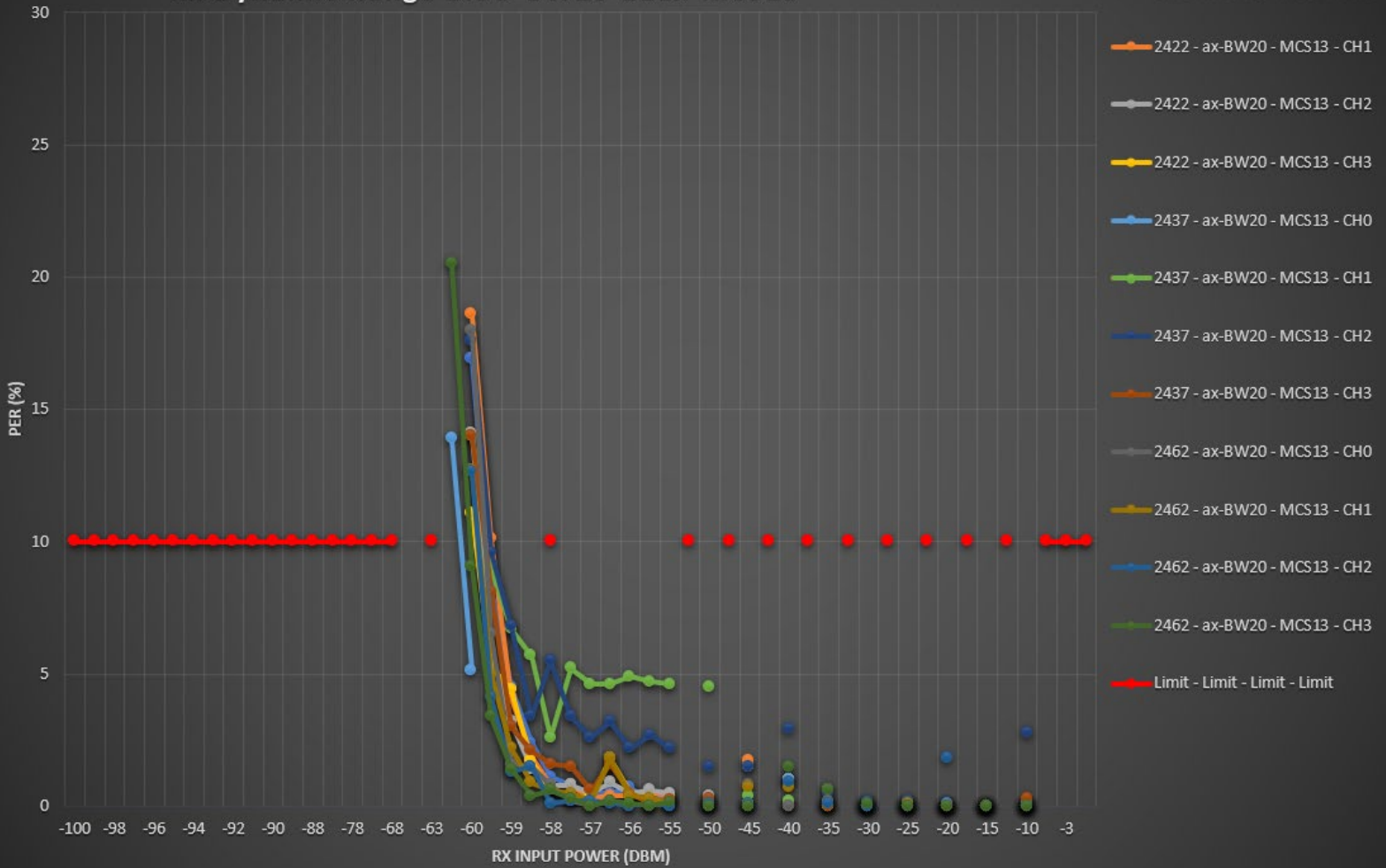

MINIPCIE (GOLD FINGER) PIN-OUT

Pin#	Description
1	WAKE_L
2	3.3V
3	RESERVED (NC)
5	RESERVED (NC)
6	1.5V (NC)
7	CLKREQ_L, connected to GND through a pull-down resistor of 0 Ohms.
8	UIM_PWR (NC)
10	UIM_DATA (NC)
11	REFCLK-
12	UIM-CLK (NC)
13	REFCLK+
14	UIM-RESET (NC)
16	UIM_VPP (NC)
17	UIM_C8 (NC)
19	UIM_C4 (NC)
20	W_DISABLE_L (Pulled up to 3.3V)
22	RESET
23	PERNO
24	3.3VAUX (NC)
25	PERPO
28	1.5V (NC)
30	SMB_CLK (NC)
31	PETNO
32	SMB_DATA(NC)
33	PETPO
36	USB_D- (NC)
37	RESERVED (NC)
38	USB_D+ (NC)
39	3.3V
41	3.3V
42	LED_WWAN_L (NC)
44	LED_WLAN_L (NC)
45	5V (FOR PA)
46	LED_WPAN_L (NC)
47	5V (FOR PA)
48	1.5V (NC)
49	5V (FOR PA)
51	5V (FOR PA)
52	3.3V
4,9,15,18,21,26,27,29,34,35,40,43,50	GND

NC- NO CONNECTION

MECHANICAL DIMENSIONS

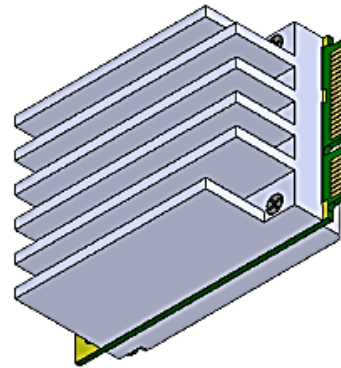
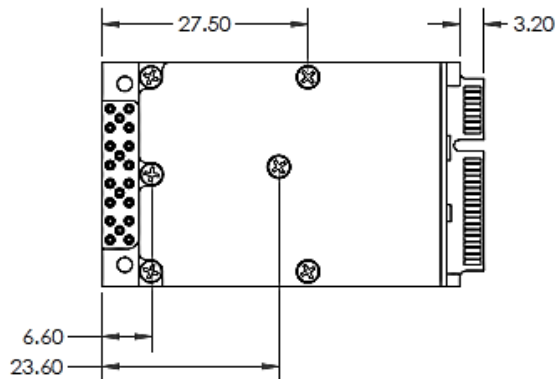
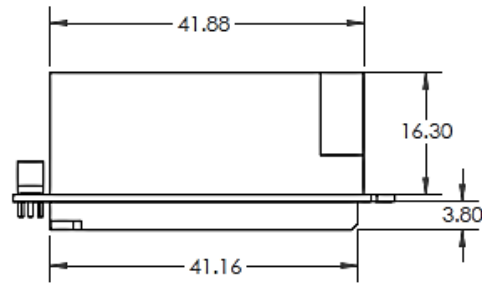
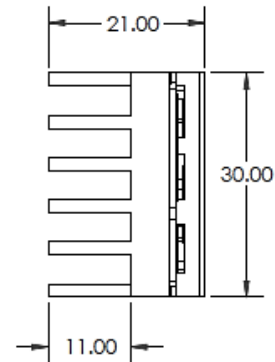
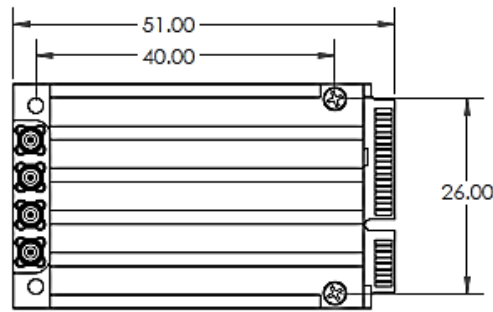

Trademarks

The information in this document is being provided in connection with Vizmonet products, which are subject to continuous developments and improvements. While every effort is made to ensure that the information contained in this document is correct and accurate at the time of this printing, Vizmonet makes no representations or warranties with respect to the accuracy of the information and is not liable for errors or mistakes that may arise. However, Vizmonet reserves the right to make changes to specifications and product descriptions at any time without notice. Vizmonet does not assume any responsibility for the use of the described product; neither does it convey any license under its patent rights, or the rights of others. Vizmonet products are not intended, authorized, or warranted for use as components in applications intended to support or sustain life. Built-to-Customize™ is a trademark of Vizmonet. All other trademarks, registered trademarks and product names are the sole property of their respective owners.

Contact

Web: <https://vizmonet.com>
Email: enquiry@vizmonet.com

Headquarters

Vizmonet Pte Ltd
21, Woodlands Close
#03-01, Primz Biz Hub
Singapore 737 854

HW REV#
axE42400.0100